

# AMS-4500<sup>®</sup> HIGH SPEED

## AMS SERIES DIRECT DRIVES

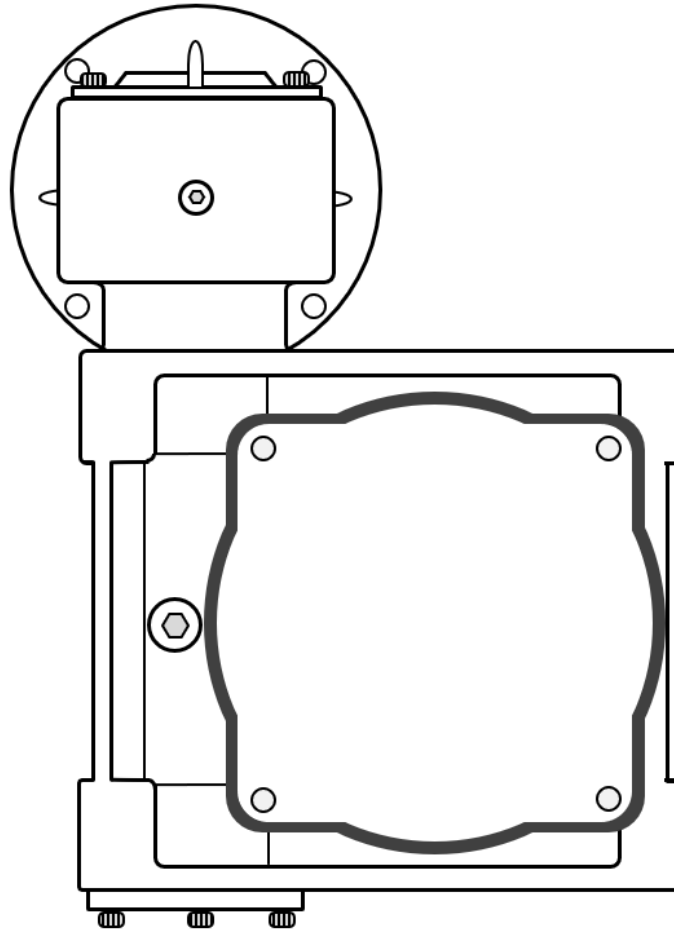





Copyright® 2024 by Aqua Marine Supply/Hefty Hoist, Inc.  
No portion of this manual or any artwork contained herein may be reproduced in any shape or form without the express written consent of Aqua Marine Supply/Hefty Hoist, Inc. Diagrams within this manual may not be drawn proportionally and/or be oversimplified for demonstration purposes. Due to continuing improvements, actual product may differ slightly from the product described herein.

### **⚠ WARNING**

**Read this material before using this product. Failure to do so can result in serious injury. SAVE THIS MANUAL**

## Table of Contents

Safety .....	2	Operating the AMS Series .....	7
Overview .....	3	Specifications .....	7
Mounting Dimensions .....	4	Max Load & Speed Chart .....	8
Installation Information .....	5	Warranty .....	9
Mounting the Electric Motor .....	6	Troubleshooting .....	10-11

WARNING SYMBOLS AND DEFINITIONS	
	This is the safety alert symbol. It is used to alert you to potential personal injury hazards. Obey all safety messages that follow this symbol to avoid injury or death
	Indicates a hazardous situation which, if not avoided, will result in death or serious injury
	Indicates a hazardous situation which, if not avoided, Could result in death or serious injury
	Indicates a hazardous situation which, if not avoided, Could result in minor or moderate injury
	Addresses practices not related to personal injury

## IMPORTANT SAFETY INFORMATION

### **DANGER**

**TO PREVENT SERIOUS INJURY AND DEATH:**

### Basic Safety Information

- |   |   |
|---|---|
| <ol style="list-style-type: none"> <li>1. <b>Do not lift people or lift loads near people.</b><br/>Falling loads can injure or kill people.<br/>Do not use as elevator for human use.</li> <li>2. <b>Do not operate the hoist when load is not centered in lift</b></li> <li>3. <b>Do not operate hoist with kinked or damaged lift cables</b><br/>Inspect lift cables before every use</li> <li>4. <b>Do not operate hoist if damaged or malfunctioned in any way</b></li> </ol> | <ol style="list-style-type: none"> <li>5. <b>If servicing or replacing parts, ensure the load is removed and cables are slack</b></li> <li>6. Lift should be installed in a location that allows the operator to move and stay clear of the load</li> <li>7. Keep clear of moving parts during operation</li> <li>8. Electrical equipment should only be installed and maintained by a qualified electrician</li> </ol> |
|---|---|

**Overview & Features**

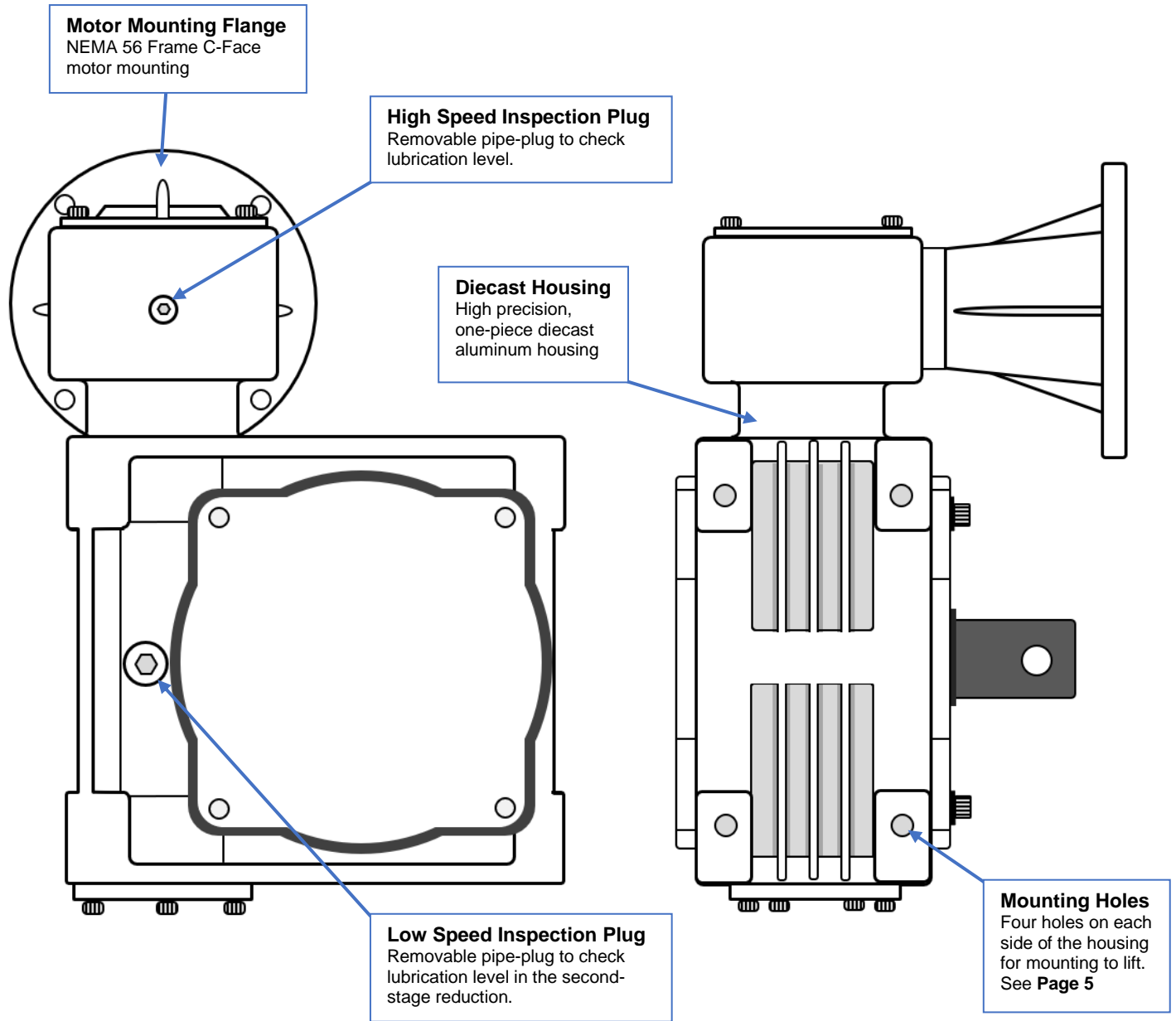

**General Description**

The AMS-4500® is an electric-powered, fully enclosed mechanical gear-driven hoist intended for use primarily in boat lifts, but also cargo lifts and other specialized applications. The gearing is intentionally designed to be inefficient to hold the rated load without the need for other equipment such as a brake motor. The AMS-4500® utilizes a helical gear set which produces industry-leading speed for its rated output torque.

**Mounting Dimensions**

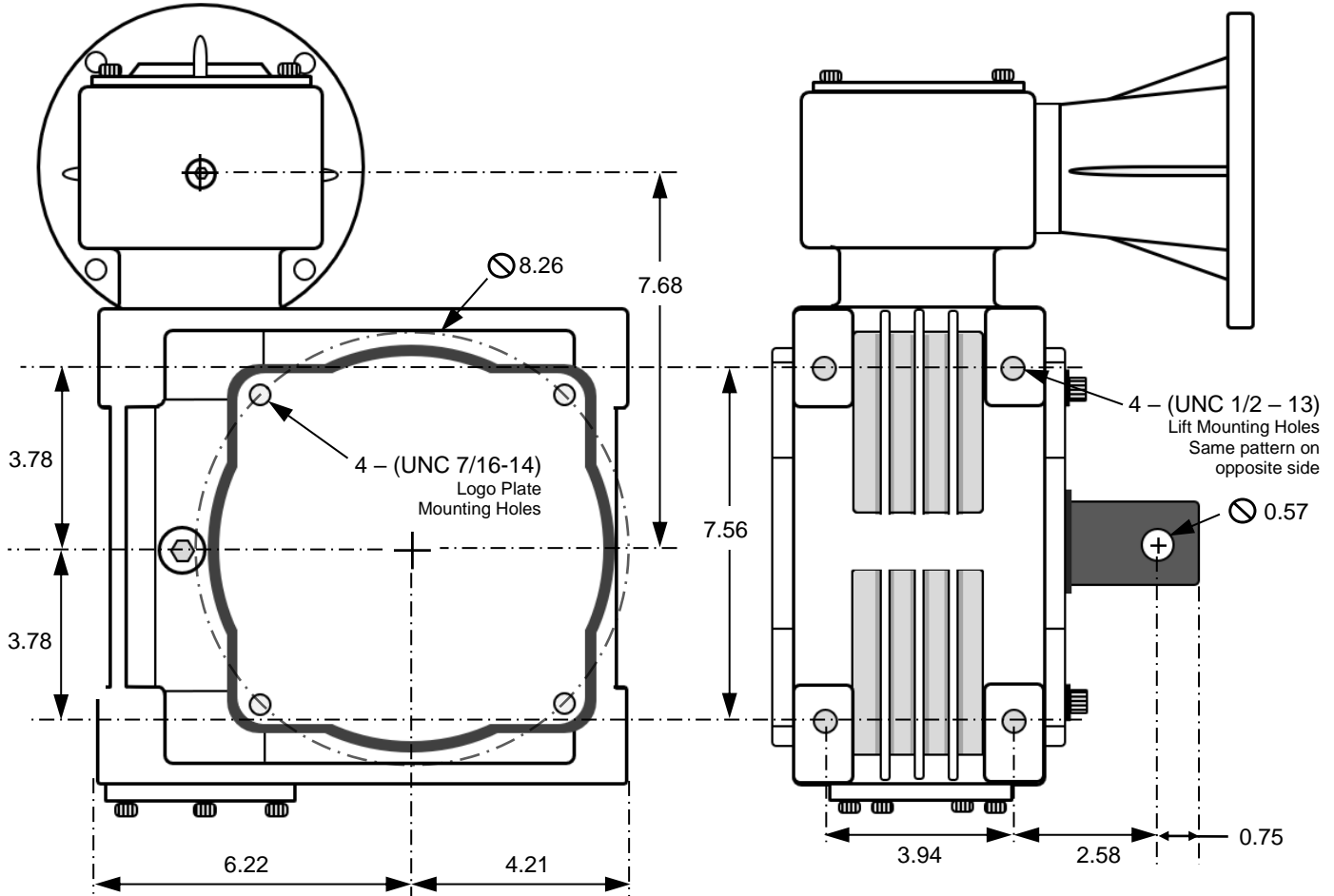

**Technical Information**

**MODELS**

The AMS-4500® High Speed is one of the three right-angle drives offered under the AMS Series line that feature fully enclosed, double-reduction gears, diecast aluminum housings, and smooth, quiet operation. The AMS-4500® features a helical gear set providing a 198:1 gear ratio and is paired with a 1-1/2 HP electric motor.

*Considering Aqua Marine Supply/Hefty Hoist does not create the entire lift, these model numbers DO NOT refer to the weight capacity of the hoist, but rather the maximum amount of torque (in inch-pounds) that they output. The diameter of the winding drum/pipe and the rigging of the lift cables (not supplied by AMS) will greatly affect the speed and weight capacity of a hoist. The lift manufacturer who utilizes our hoist and sells the lift as a package is the only party that can determine the final weight capacity.*

**Standard AMS Series Configurations**

Model	Gear Ratio	Motor HP	Motor Finish	Voltage
AMS-4000	370:1	1	Stainless Steel	115/230
AMS-4500	450:1	1 HD	Stainless Steel	115/230
AMS-4500HS	198:1	1-1/2	Stainless Steel	115/230*

\*230V required for proper operation

**SPEED & TORQUE**

Speed and torque are an inverse relationship, and anything done to speed the drive up will decrease its output torque. The standard AMS® models are designed to operate with a 1725 RPM motor and are not rated for use with a 3450 RPM. Doing so will void the warranty.

Installation Information

**NOTICE**

**CAUTION**

**Alignment:** It is important that the AMS-4500® be mounted so that the winding pipe is concentric and in line with the output shaft of the gearbox. Misalignment at this point can cause binding, wear, and noise and will void the warranty.

**Bearing Placement:** The drive shaft or winding pipe being used on the lift must be supported properly with bearings at various points. AMS drives are made to turn the pipe and are not to be load-bearing. Therefore, it is important that a support bearing be installed as close as possible to the AMS-4500®.

**Orientation:** The AMS-4500® can be mounted vertically with the motor at the highest point (12 o'clock) or rotated 90 degrees either direction (see **Figure 5**). Mounting the AMS-4500® with the motor lower than this point will void the warranty.

**Figure 5**

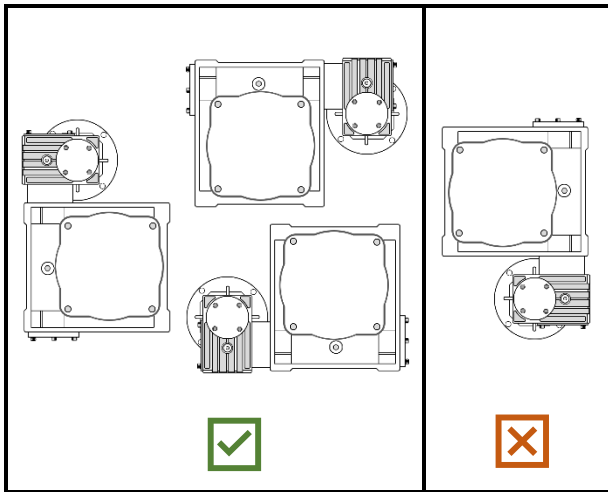

**Electrical Motor:** While the 1-1/2 HP electric motor used on the AMS-4500® can be used on a 115 or 230V circuit, it is highly recommended that only a 230V power supply be used for proper operation. The 1-1/2 HP motor provided by AMS has been custom-engineered to deliver an increased lock-rotor torque required by the helical gearbox.

**Mounting:** The AMS-4500® should be fastened to the lift piling, beam, or structural joist to prevent the hoist from rotating under operation. The AMS-4500® features a four-bolt pattern on each side of the main housing for mounting. It is recommended that holes on one side only be used for mounting. Mounting to both sides could create too rigid of a mount and

**Drive Bolt & Nut:** The provided drive bolt is a grade 5, zinc-plated, casehardened 1/2 inch bolt with yield and breaking strength far superior to the maximum load rating of the AMS-4500®. DO NOT replace this bolt with a stainless steel bolt for any reason. The provided nut is a reversible lock nut which can be installed in either direction and will lock in position similar to a nylon lock nut. This nut should NOT be tightened all the way against the gear sleeve as pressure against it could fracture the sleeve. The nut is only good for one use and should be replaced if needed to be removed for any reason.

**Winding/Drive Pipe:** The AMS-4500® is designed to attach to a 1-1/2" pipe (1.9 inch outside diameter). If a 2 inch or any other sized pipe is being used in the installation, then a spacer or adapter must be added (not provided by AMS) to take up the empty space.

**⚠WARNING**

**Failure to fill this empty space with a spacer can cause the provided drive bolt to bend or fail which could lead to catastrophic failure.**

## Mounting the Electric Motor

### **⚠ WARNING**

**TO PREVENT SERIOUS INJURY, ENSURE THE ELECTRICAL CIRCUIT IS SWITCHED OFF BEFORE PROCEEDING**

1. Install the 3/16 key into the keyway on the motor shaft.
2. Install one half of the coupling to the motor shaft as shown in Figure 6 below. For NEMA 56 frame motors, the outer face of the coupler jaws should be flush to the end of the motor shaft. Otherwise, the coupling should be installed 20 mm from the motor mounting bolt surface.

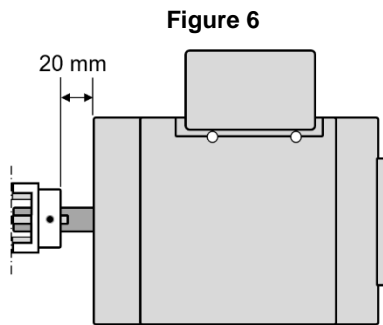

3. Tighten the set screw on the coupling with a 3mm hex key wrench.

4. Ensure that the flexible spider connector is installed on the gearbox coupling and slide the electric motor into position. Try to line the couplings up as close as possible before inserting. Wiggle the motor until the couplings engage. The motor should insert until the mounting bolt surface of the motor contacts the gearbox bell flange. If there is a gap, remove the motor and make sure that the coupling is in the correct position on the shaft as mentioned in **Step 2**.
5. Once the motor is fully inserted, rotate the motor to line up the four mounting holes with the holes in the AMS-4500® bell flange. Make sure the capacitor of the electric motor is at the highest point.
6. Secure the Electric Motor to the mounting flange with the provided hardware; (4) stainless steel 3/8-16 x 1" bolts and split lock-washers
7. If the Electric motor has removable weep hole plugs for condensation, remove the plug(s) at the lowest point to prevent moisture build-up.

## Electric Motor Connections

The provided electric motor from Aqua Marine Supply/Hefty Hoist, Inc® is a 115/230V, single phase, reversible motor that should only be installed by a qualified electrician. The electrical circuit should be GFCI protected and should contain the proper size wiring to ensure full voltage to the motor on the hoist. Failure to supply the correct and full electrical voltage to the motor or failing to make the proper connections will permanently damage the motor and is not covered by warranty.

For electric motors that were not wired to controls from factory, wiring schematics can be found at [www.HeftyHoist.com/wiring-diagrams](http://www.HeftyHoist.com/wiring-diagrams). Please do not contact us with questions about compatibility with non-AMS equipment as we will not be able to assist.

## Before Operating Hoist

1. Familiarize yourself with all operating controls of the hoist and with the operation(s) of the manufacturer's lift. Also familiarize yourself with the instructions, including the warning(s) on the hoist and lift and with the safety information within this manual. Read all information provided by the lift manufacturer regarding your specific lift.
2. **TO PREVENT SERIOUS INJURY FROM LIFT FAILURE:**  
**Do not use damaged equipment. If repairs are necessary or any defect known, have the issues corrected before use.**
3. Inspect the Hoist and other lift components thoroughly before use.

## Operating the AMS-4500®

### For AMS Reversing Switch installations:

Rotate the switch handle to the desired lifting direction (UP or DOWN). See Figure 6

**NOTE:** A **Momentary** style switch will require the user to hold the handle in the desired operating position and if released, the handle should return to the OFF position automatically. A **Maintaining** style switch will allow the switch handle to maintain the position selected throughout operation and the handle needs to be rotated back by the user to the OFF position when finished.

### For Remote Control installations:

Follow directions provided by the Remote Control manufacturer for proper operation

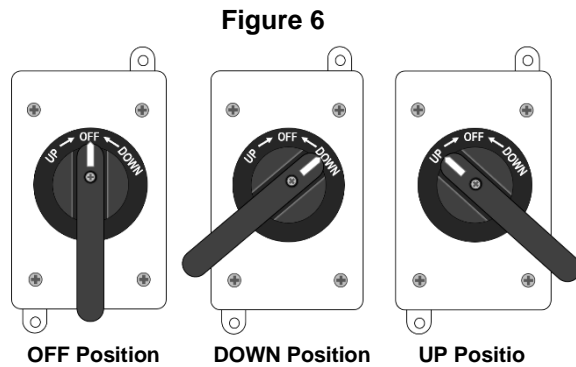

## Maintenance Information

The design of the AMS-4500® eliminates the need for periodically lubricating grease fittings such that you would find on exposed gear hoists. However, it is still recommended that the gearbox be inspected by a qualified technician at least once per season to maintain warranty. A record of such inspection may be required if warranty is attempted to be claimed by the user.

### Lubricant Type

The AMS-4500® is factory-filled with a combination of **Mobilux EP 023** semi-fluid grease and **Mobil SHC 634** synthetic gear oil which are specially formulated lubricants for enclosed gearboxes.

## Specifications

<b>AMS-4500®</b>	
Torque Rating	4,500 in-lb
Gear Ratio	198:1
Rated Motor HP	1.5
Motor Amps (115 / 230V)	15.2 / 7.6
Rated Motor RPM	1725
Output RPM	8.71
Lubricant Type	1st Reduction Stage: Mobil SHC 634 2nd Reduction Stage: Mobilux EP 023
Lubricant Capacity	1st Reduction Stage: 8.5 oz (0.26 qt) 2nd Reduction Stage: 40.6 oz (1.27 qt)
Weight	Gearbox Packaged: 69 lb Gearbox Only: 67 lb Installed with motor: 102 lb
Output Shaft Size	1.50"
Straight-pull maximum load (see <b>Page 8</b> )	4,500 lb - 1.5" winding surface (1.9" OD) 3,789 lb - 2" winding surface (2.375" OD)

**Max Load & Lift Speed Chart**

The chart on the following page can be used to determine the maximum load a particular model AMS-4500® can lift based on the winding pipe and cable configuration. The chart only accommodates for lifts with one AMS-4500®; if multiple gear drives are used on the same lift, then multiply the Max Load value in the chart by the number of AMS-4500® drives on the lift.

\* "Winding Pipe" refers to the surface where the cable actually winds up. If a sleeve, winder, or spool is used over the nominal drive pipe, use the OD of that item and see corresponding line in chart (see **Figure 9a**). The chart assumes neatly wrapped lift cable and does not accommodate for overlap which will affect speed and max load.

\*\* See **figure 9b** for Cable Compounding information

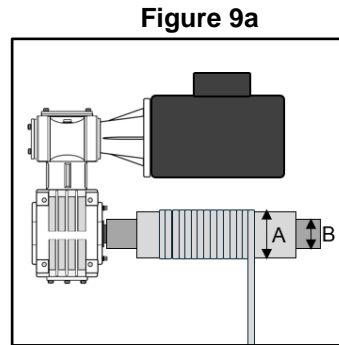

In the above example, dimension "A" would be used as the winding pipe value in the load chart, not "B"

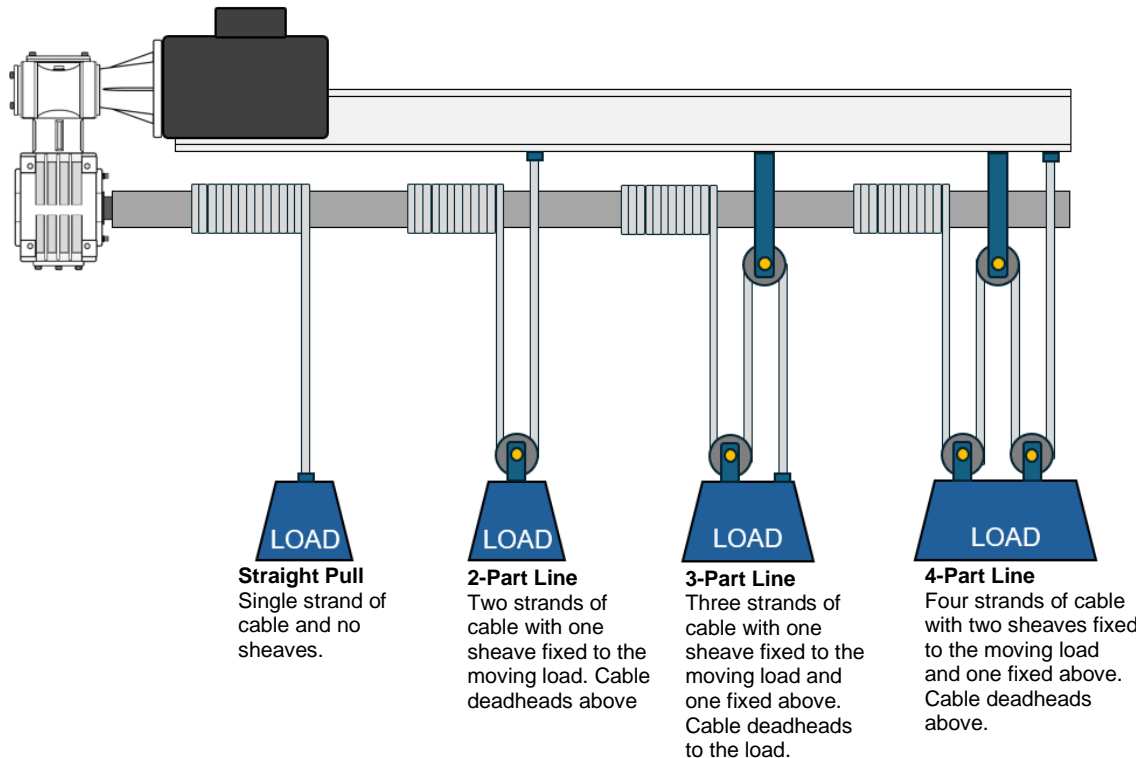

**Straight Pull**  
Single strand of cable and no sheaves.

**2-Part Line**  
Two strands of cable with one sheave fixed to the moving load. Cable deadheads above

**3-Part Line**  
Three strands of cable with one sheave fixed to the moving load and one fixed above. Cable deadheads to the load.

**4-Part Line**  
Four strands of cable with two sheaves fixed to the moving load and one fixed above. Cable deadheads above.

		AMS-4500®	
Winding Pipe	Lift Cable Compounding	Max Load per Hoist (Lb)	Vertical Speed (in/min)
1.5" Pipe (1.9" OD)	Straight Pull	4,500	52.0
	2 Part Line	8,526	26.0
	3 Part Line	12,079	17.3
	4 Part Line	15,158	13.0
2" Pipe (2.38" OD)	Straight Pull	3,789	65.0
	2 Part Line	6,821	32.5
	3 Part Line	9,663	21.7
2.5" Pipe (2.88" OD)	Straight Pull	3,130	78.7
	2 Part Line	5,635	39.3
	3 Part Line	7,983	26.2
3" Pipe (3.5" OD)	Straight Pull	10,017	19.7
	2 Part Line	2,571	95.8
	3 Part Line	4,629	47.9
3.5" Pipe (4" OD)	4 Part Line	6,557	31.9
	Straight Pull	2,250	109.5
	2 Part Line	4,050	54.7
4" Pipe (4.5" OD)	3 Part Line	5,738	36.5
	4 Part Line	7,200	27.4
	Straight Pull	2,000	123.2
4.5" Pipe (5.56" OD)	2 Part Line	3,600	61.6
	3 Part Line	5,100	41.1
	4 Part Line	6,400	30.8
5" Pipe (6.63" OD)	Straight Pull	1,618	152.3
	2 Part Line	2,912	76.1
	3 Part Line	4,125	50.8
6" Pipe (8.0" OD)	4 Part Line	5,177	38.1
	Straight Pull	1,358	181.3
	2 Part Line	2,445	90.7
6.5" Pipe (8.63" OD)	3 Part Line	3,464	60.4
	4 Part Line	4,347	45.3



## PLEASE READ THE FOLLOWING CAREFULLY

THE PARTS LIST AND ASSEMBLY DIAGRAMS IN THIS MANUAL ARE A REFERENCE TOOL ONLY. WE DO NOT MAKE ANY REPRESENTATION OR WARRANTY OF ANY KIND TO THE BUYER THAT THEY ARE QUALIFIED TO MAKE ANY REPAIRS OR REPLACE ANY PARTS OF THE PRODUCT. IN FACT, AQUA MARINE SUPPLY/HEFTY HOIST, INC EXPRESSLY STATES THAT ALL REPAIRS SHOULD BE UNDERTAKEN BY CERTIFIED AND LICENSED TECHNICIANS, AND NOT BY THE BUYER. THE BUYER ASSUMES ALL RISK AND LIABILITY ARISING OUT OF HIS OR HER REPAIRS TO THE ORIGINAL PRODUCT OR REPLACEMENT PARTS THERETO, OR ARISING OUT OF HIS OR HER INSTALLATION OF REPLACEMENT PARTS THERETO.

### Warranty

The following warranty applies to the components of the models of hoists manufactured by Hefty Hoist, Inc dba Aqua Marine Supply®. This warranty applies to manufacturing defects and/or failures due to design or fabrication. Replacement parts or a new product will be supplied at no charge at the option of Aqua Marine Supply. This does NOT include labor or freight.

- Electrical components including electric motor, wire, switch, GFCI power cords (1 Year)
- AMS-4500® gearbox components (2 Years)

This warranty is void if product is improperly installed, maintained or greased. Any changes or alterations to the original design will also void the warranty. The warranty does not cover acts of nature or criminal activity. The warranty is predicated on proof of annual inspection by a qualified technician and a record of inspection must be presented for any warranty claim. The warranty applies only to the original owner and is void if transfer of ownership.

To take advantage of this warranty, the product must be returned to us for evaluation with transportation charges prepaid (unless otherwise directed). Proof of purchase date and an explanation of the complaint must accompany the product otherwise no warranty will be given and the product will only be returned at the cost of the sender.



## Troubleshooting

Problem	Possible Causes	Probable Solutions
Electric motor getting hot  <i>Note: Limit use as much as possible when this occurs. Permanent, irreversible damage could be done to the electric motor</i>	<ol style="list-style-type: none"> <li>1. Low voltage due to insufficient wire size (most common)</li> <li>2. Improper wiring connections</li> <li>3. Mechanical binding in lift adding additional stress</li> </ol>	<ol style="list-style-type: none"> <li>1. Have the voltage checked under load at the motor by a qualified electrical professional. If voltage drop present, check wire size from main panel and ensure sufficient size for the length of the run based on the amp draw of the motor(s) on the AMS-4500®. <i>Note: If possible, switch a 115V installation to 230V</i></li> <li>2. Ensure the electrical connections are correctly made at the electric motor as well as the control. See HeftyHoist.com for wiring schematics</li> <li>3. Check lift components according to lift manufacturers instructions for binding including lubricating sheaves and guides.</li> </ol>
Electric motor humming in one or both directions	For new installations: <ol style="list-style-type: none"> <li>1. Improper connections</li> <li>2. Defective motor or control</li> </ol> For existing installations: <ol style="list-style-type: none"> <li>1. Corrosion</li> <li>2. Damaged wiring</li> </ol>	For new installations: <ol style="list-style-type: none"> <li>1. Ensure the electrical connections are correctly made at the electric motor as well as the control (switch or remote control panel). See HeftyHoist.com for wiring schematics</li> <li>2. Have electrician try to isolate issue is either at the electric motor or control and replace as necessary.</li> </ol> For existing installations: <ol style="list-style-type: none"> <li>1. Have electrician check connections at motor and control for corrosion not allowing full power through. Issue may be internal and faulty item may need replaced.</li> <li>2. Inspect wiring circuit from control to electric motor for possible damage and repair/replace as necessary.</li> </ol>
Electric motor does nothing	<ol style="list-style-type: none"> <li>1. GFCI has tripped</li> <li>2. Circuit breaker has tripped</li> <li>3. Open circuit</li> </ol>	<ol style="list-style-type: none"> <li>1. Check all GFCI including the one provided by AMS on the power cord if applicable and reset.</li> <li>2. Check the circuit breaker belonging to the lift and reset if turned off. If breaker continues to trip:           <ol style="list-style-type: none"> <li>a. Check if breaker defective</li> <li>b. If breaker working properly, there is a dead short somewhere in the circuit from the breaker to the electric motor. DO NOT use hoist and consult an electrician right away</li> </ol> </li> <li>3. Electrical circuit is open at some point from the breaker to the electric motor. Consult an electrician to isolate the issue</li> </ol>
Electric motor is full of water inside	<ol style="list-style-type: none"> <li>1. Motor submerged during flooding/storm surge</li> <li>2. Motor was not mounted in correct orientation</li> <li>3. Weep hole plugs were not removed</li> </ol>	<ol style="list-style-type: none"> <li>1-3 Replace the motor and ensure it is mounted in correct orientation and that the weep hole drain plugs are removed at the lowest point in the new installation.</li> </ol>
More noisy in one direction than other	<ol style="list-style-type: none"> <li>1. Normal operation</li> <li>2. Bearing placement/overloading/ misalignment</li> <li>3. Low oil level in high speed chamber</li> </ol>	<ol style="list-style-type: none"> <li>1. It is normal for the AMS-4500® to be slightly noisier in one direction than the other due to gear geometry.</li> <li>2. Check for misalignment, support bearing placement on lift, binding at sheaves or guides and possibility of lift being overloaded by some margin.</li> <li>3. Inspect the high speed chamber for lubricant level.</li> </ol>

Problem	Possible Causes	Probably Solutions
Lift stops as soon as boat comes fully out of water	<ol style="list-style-type: none"> <li>1. Low voltage due to insufficient wire size</li> <li>2. Mechanical binding in lift adding additional stress</li> <li>3. Overloaded</li> </ol>	<ol style="list-style-type: none"> <li>1. Have the voltage checked under load at the motor by a qualified electrical professional. If voltage drop present, check wire size from main panel and ensure sufficient size for the length of the run based on the amp draw of the motor(s) on the AMS-4500®. <i>Note: If possible, switch a 115V installation to 230V</i></li> <li>2. Check lift components according to lift manufacturers instructions for binding including lubricating sheaves and guides.</li> <li>3. Ensure that the load is within limits of the AMS-4500 as well as within the rated capacity of the lift set by the lift manufacturer.</li> </ol>
Drive bolt bending or breaking	<ol style="list-style-type: none"> <li>1. Shock load from cable hanging up temporarily and the lift falling some inches</li> <li>2. Empty space between the hoist and the drive pipe not filled with a spacer or adapter</li> <li>3. Bolt was replaced with a stainless steel bolt</li> </ol>	<ol style="list-style-type: none"> <li>1. Inspect AMS-4500® and rest of lift for damages. Highly recommend contacting lift manufacturer or service technician to inspect culprit and/or resulting damages. Replace with new G5 or G8 bolt/nut</li> <li>2. A spacer or adapter must be fabricated/sourced to fill any empty space between the drive pipe and the opening in the main gear assembly</li> <li>3. Replace with correct Grade 5 or 8 bolt immediately</li> </ol>



**ALL TROUBLESHOOTING, MAINTENANCE, AND REPAIR SHOULD BE COMPLETED ONLY BY A LICENSED PROFESSIONAL AND/OR ELECTRICIAN. FOLLOW ALL WARNING LABELS ON THE HOIST OR SERIOUS INJURY COULD OCCUR**